

Ozone Analyzer

OPERATION MANUAL

Model UV-106

TABLE OF CONTENTS

| | |
|-------------------------------------|-----|
| IDENTIFICATION RECORDS..... | iii |
| PRINTING HISTORY..... | iv |
| WARRANTY STATEMENT..... | v |
| 1. OZONE ANALYZER INTRODUCTION..... | 1 |
| 2. OPERATION..... | 5 |
| 3. MAINTENANCE/TROUBLESHOOTING..... | 16 |
| 4. PARTS LIST..... | 17 |
| 5. CONTACTING OZONE SOLUTIONS..... | 18 |

IDENTIFICATION RECORDS

Record the following information for future reference:

Unit serial number: _____

Warranty start date: _____
(date of receipt)

PRINTING HISTORY

New editions are complete revisions of the manual and incorporate all previous update pages and write-in instructions. This manual will be revised as necessary. Revisions can be in the form of new editions, update pages, or write-in instructions.

Revision A.....May 2006

Revision B.....June 2007

CONFIDENTIALITY

The information contained in this manual may be confidential and proprietary, and is the property of Ozone Solutions, Inc. Information disclosed herein shall not be used to manufacture, construct, or otherwise reproduce the goods disclosed herein. The information disclosed herein shall not be disclosed to others or made public in any manner without the expressed written consent of Ozone Solutions, Inc.

WARRANTY STATEMENT

Ozone Solutions, Inc. warrants its products against defects in materials and workmanship. Ozone Solutions will, at its option, repair or replace products which prove to be defective. The warranty set forth is exclusive and no other warranty, whether written or oral, is expressed or implied. Ozone Solutions specifically disclaims the implied warranties of merchantability and fitness for a particular purpose.

Warranty Periods

The warranty period is one (1) year from date of receipt by the purchaser, but in no event more than thirteen (13) months from original invoice date from Ozone Solutions, Inc.

Warranty Service

Warranty Service is provided to customers through phone support, Monday - Friday, from 8:00 a.m. to 5:00 p.m., Central Time USA. Phone support is for trouble-shooting and determination of parts to be shipped from Ozone Solutions to the customer in order to return the product to operation within stated specifications. If phone support is not efficient and effective, the product may be returned to Ozone Solutions for repair or replacement. Prior to returning the product, a Repair Material Authorization Number (RMA) must be obtained from the Ozone Solutions Service Department.

Shipping

Ozone Solutions will pay freight charges for replacement or repaired products shipped to the customer site. Customers shall pay freight charges for all products returning to Ozone Solutions.

Conditions

The foregoing warranty shall not apply to defects resulting from improper or inadequate maintenance, adjustment, calibration or operation by customer. Maintenance, adjustment, calibration or operation must be performed in accordance with instructions stated in the Ozone Analyzer manual. Usage of maintenance materials purchased from suppliers other than Ozone Solutions will void this warranty.

Limitation of Remedies and Liability

The remedies provided herein are the Customer's sole and exclusive remedies. In no event shall Ozone Solutions be liable for direct, indirect, special, incidental or consequential damages (including loss of profits) whether based on contract, tort or any other legal theory. The Ozone Analyzer manual is believed to be accurate at the time of publication and no responsibility is taken for any errors that may be present. In no event shall Ozone Solutions be liable for incidental or consequential damages in

connection with or arising from the use of the Ozone Analyzer manual and its accompanying related materials. Warranty is valid only for the country designated on the Ozone Solutions quote or invoice.

ENGLISH

 **WARNING:**
Any operation requiring access to the inside of the equipment, could result in injury. To avoid potentially dangerous shock, disconnect from power supply before opening the equipment.

WARNING:
This symbol,  on the instrument indicates that the user should refer to the manual for operating instructions.

WARNING:
If this instrument is used in a manner not specified by Ozone Solutions, Inc. USA, the protection provided by the instrument may be impaired.

ESPAÑOL

 **ATENCIÓN:**
Cualquier operación que requiera acceso al interior del equipo, puede causar una lesión. Para evitar peligros potenciales, desconectarlo de la alimentación a red antes de abrir el equipo.

ATENCIÓN:
Este símbolo,  en el instrumento indica que el usuario debería referirse al manual para instrucciones de funcionamiento.

ATENCIÓN:
Si este instrumento se usa de una forma no especificada por Ozone Solutions, Inc., USA, puede desactivarse la protección suministrada por el instrumento.

FRANÇAIS

 **ATTENTION:**
Chaque opération à l'intérieur de l'appareil, peut causer du préjudice. Afin d'éviter un shock qui pourrait être dangereux, déconnectez l'appareil du réseau avant de l'ouvrir.

ATTENTION:
Le symbol,  indique que l'utilisateur doit consulter le manuel d'instructions.

ATTENTION:
Si l'instrument n'est pas utilisé suivant les instructions de Ozone Solutions, Inc., USA, les dispositions de sécurité de l'appareil ne sont plus valables.

DEUTSCH

 **WARNHINWEIS:**
Vor dem Öffnen des Gerätes Netzstecker ziehen!

WARNHINWEIS:
Dieses,  auf dem Gerät weist darauf hin, daß der Anwender zuerst das entsprechende Kapitel in der Bedienungsanleitung lesen sollte.

WARNHINWEIS:
Wenn das Gerät nicht wie durch die Firma Ozone Solutions, Inc., USA, vorgeschrieben und im Handbuch beschrieben betrieben wird, können die im Gerät eingebauten Schutzvorrichtungen beeinträchtigt werden.

ITALIANO

 **ATTENZIONE:**
Qualsiasi intervento debba essere effettuato sullo strumento può essere potenzialmente pericoloso a causa della corrente elettrica. Il cavo di alimentazione deve essere staccato dallo strumento prima della sua apertura.

ATTENZIONE:
Il simbolo,  sullo strumento avverte l'utilizzatore di consultare il Manuale di Istruzioni alla sezione specifica.

ATTENZIONE:
Se questo strumento viene utilizzato in maniera non conforme alle specifiche di Ozone Solutions, Inc. USA, le protezioni di cui esso è dotato potrebbero essere alterate.

DUTCH

 **OPGELET:**
Iedere handeling binnenin het toestel kan beschadiging veroorzaken. Om iedere mogelijk gevaarlijke shock te vermijden moet de aansluiting met het net verbroken worden, vóór het openen van het toestel.

OPGELET:
Het symbool,  geeft aan dat de gebruiker de instructies in de handleiding moet raadplegen.

OPGELET:
Indien het toestel niet gebruikt wordt volgens de richtlijnen van Ozone Solutions, Inc., USA gelden de veiligheidsvoorzieningen niet meer.

1. OZONE ANALYZER INTRODUCTION

The Ozone Solutions' Model UV-106 Ozone Analyzer is designed to enable accurate measurements of ozone in air over a wide dynamic range extending from a limit of detection of 1.5 parts-per-billion by volume (ppbv) to an upper limit of 100 parts-per-million (ppmv) based on the well established technique of absorption of ultraviolet light at 254 nm. The Ozone Analyzer is light weight (4.2 lb., 1.9 kg.) and has a low power consumption (≈ 3.6 watt) relative to conventional instruments and is therefore well suited for applications such as:

- long-term analyzing at remote locations where power is highly limited
- urban arrays of ground-based detectors
- personal exposure analyzing for studies of health effects of air pollutants

For aircraft flights where high temporal resolution is desired, the Model 205 Ozone Analyzer is recommended.

Theory of Operation

Absorption of UV light has long been used for measurements of atmospheric ozone with high precision and accuracy. The ozone molecule has an absorption maximum at 254 nm, coincident with the principal emission wavelength of a low-pressure mercury lamp. Fortunately, few molecules found at significant concentrations in the atmosphere absorb at this wavelength. However, interferences, such as organic compounds containing aromatic rings, can occur in highly polluted air.

Figure 1 is a schematic diagram of the Ozone Analyzer. Ozone is measured based on the attenuation of light passing through a 14-cm long absorption cell fitted with quartz windows. A low-pressure mercury lamp is located on one side of the absorption cell, and a photodiode is located on the opposite side of the absorption cell. The photodiode has a built-in interference filter centered on 254 nm, the principal wavelength of light emitted by the mercury lamp. An air pump draws sample air into the instrument at a flow rate of approximately 1 L/min. A solenoid valve switches so as to alternately send this air directly into the absorption cell or through an ozone scrubber and then into the absorption cell. The intensity of light at the photodiode is measured in air that has passed

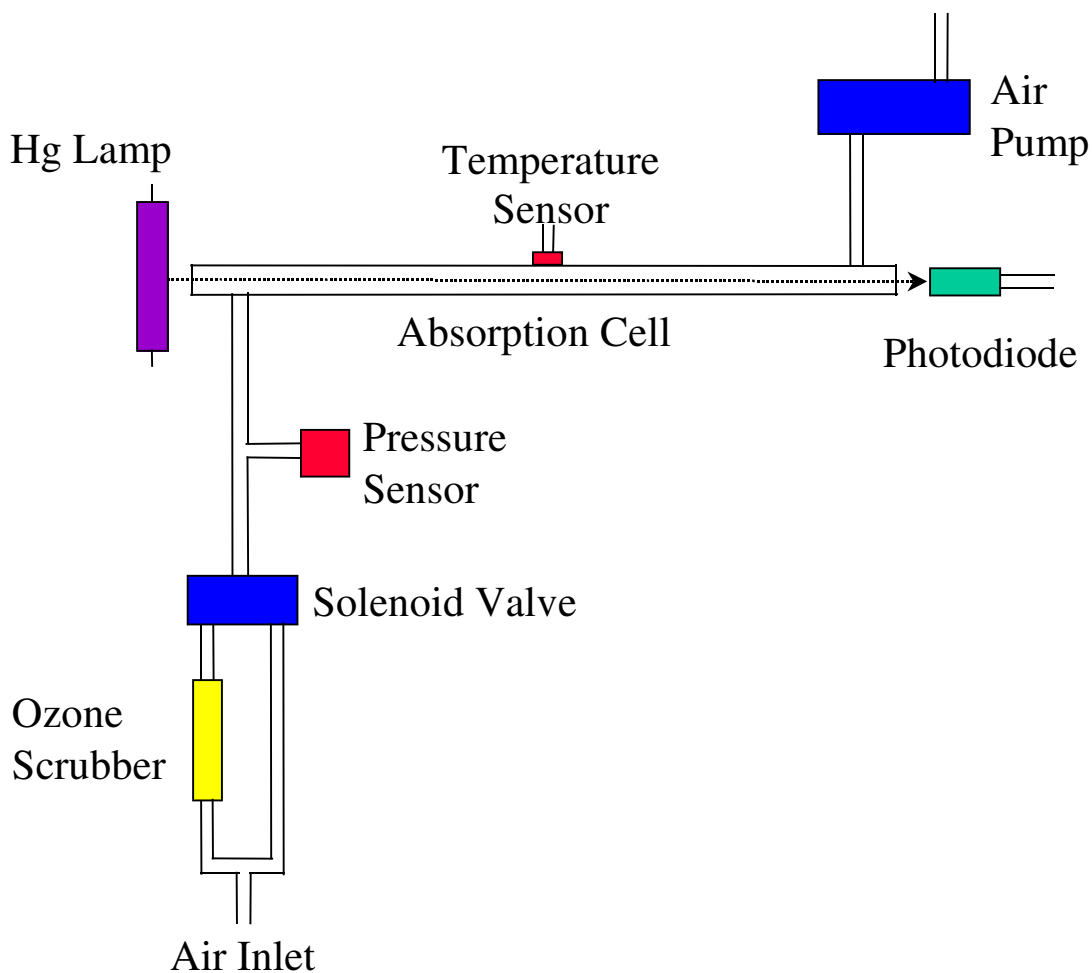

Figure 1. Schematic diagram of the ozone instrument.

through the ozone scrubber (I_o) and air that has not passed through the scrubber (I). Ozone concentration is calculated from the measurements of I_o and I according to the Beer-Lambert Law:

$$C_{O_3} = \frac{1}{\sigma l} \ln\left(\frac{I_o}{I}\right)$$

where l is the path length (15 cm) and σ is the absorption cross section for ozone at 254 nm ($1.15 \times 10^{-17} \text{ cm}^2 \text{ molecule}^{-1}$ or $308 \text{ atm}^{-1} \text{ cm}^{-1}$), which is known with an accuracy of approximately 1%. The Ozone Solutions instrument uses the same absorption cross section (extinction coefficient) as used in other commercial instruments.

The logarithm of equation 1 is approximated in the microprocessor of the instrument with sufficient accuracy to provide five orders of dynamic range; ozone mixing ratios are measured up to 100 ppmv, as compared to 1 ppmv for most commercial ozone instruments.

The pressure and temperature within the absorption cell are measured so that the ozone concentration can be expressed as a mixing ratio in parts-per-billion by volume (ppbv). The instrument displays and records the cell temperature and pressure in addition to the ozone mixing ratio. The cell pressure is displayed and logged in units of mbar and the cell temperature in units of either °C.

In principle, the measurement of ozone by UV absorption requires no external calibration; it is an absolute method. However, non-linearity of the photodiode response and electronics can result in a small measurement error. Therefore, each instrument is compared with a NIST-traceable standard ozone spectrophotometer in the laboratory over a wide range of ozone mixing ratios. These results are used to calibrate the Ozone Analyzer with respect to an offset and slope (gain or sensitivity). The corrections for offset and slope are recorded in the instrument Birth Certificate and on a calibration sticker that can be viewed by removing the front cover of the instrument. These calibration parameters are entered into the microprocessor prior to shipment. The user may change the calibration parameters from the front panel if desired. It is recommended that the instrument be recalibrated at least once every year and preferably more frequently. The offset may drift due to temperature change or chemical contamination of the absorption cell. As discussed below, an accurate offset correction can be measured from time to time using the external ozone scrubber supplied with the instrument.

OZONE ANALYZER SPECIFICATIONS

Power Requirements.....11-14 V DC, nominally 300 mA at 12 V, 3.6 watt

Dimensions.....4" x 7.5" x 8.5" (10.1 x 18.8 x 21.6 cm)

Weight4.2 lbs (1.9 kg)

Precision.....greater of 1.5 ppbv or 2%

Accuracy.....greater of 1.5 ppbv or 2%

2. OPERATION

Please read all the following information before attempting to install the Ozone Analyzer. For assistance, please call Ozone Solutions at (712) 722-0337.

NOTE:

Save the shipping carton and packing materials that came with the Ozone Analyzer. If the Ozone Analyzer must be returned to the factory, pack it in the original carton. Any repairs as a result of damage incurred during shipping will be charged.

Shipping Box Contents

Open the shipping box and verify that it contains the following:

1. Ozone Analyzer
2. 110-220 V AC power adapter
3. Cigarette lighter adapter
4. Bare-wire 12 V DC battery adapter
5. RS-232 Serial port cable
6. Zeroing cartridge
7. Ozone Analyzer manual
8. Ozone Analyzer birth certificate (inside manual)
9. Quality control data sheet and graph (inside manual)

If anything is missing or obviously damaged, contact Ozone Solutions immediately.

Operation of the Ozone Analyzer

To operate the Ozone Analyzer, connect it to an external power source and turn the instrument on by flipping the power switch on the back panel. The instrument requires a 12 V DC source which can be supplied by: 1) the 110-220 V AC power adapter, 2) a cigarette lighter adapter plugged into a 12 V DC source such as found in an automobile or many light aircraft, or 3) a 12 V battery. The source can be in the range 11-14 V DC without any detrimental effects on the measurement. When using a battery, be certain to attach the positive (red) and negative (black) wires correctly. Batteries and battery chargers are available from Ozone Solutions. A circuit breaker and diode are

installed on the circuit board in case of an electrical short or incorrect battery attachment. If activated, the breaker will reset itself after a few minutes.

Lead-acid batteries are available from numerous manufacturers in a wide range of sizes and amp-hour ratings. The larger of these, such as those for automobiles or boats, will supply power for up to several weeks. Battery packs in the correct voltage range may be constructed from nickel-cadmium (rechargeable) or lithium (light weight but not rechargeable) batteries for operation for a few hours. Battery options available through Ozone Solutions may be found on our webpage: www.ozonesupplies.com

Once turned on, the instrument will display the version number of the software installed on the microprocessor. After a few seconds, the instrument will start displaying readings for ozone. The first dozen readings (requiring about two minutes) will be spurious, with large positive and negative swings due to the rapid warm-up of the lamp and electronics. Also, ozone readings may be inaccurate during the 10-20 minutes required for the lamp, photodiode, and internal temperature of the absorption cell to stabilize.

Inlet tubing may be attached to the 1/4 inch nylon Swagelok fitting on the back of the instrument. The inlet tubing should be made of PTFE (Teflon[®], PFA, FEP, PVDF or some other inert material that does not destroy ozone and that does not desorb plasticizers and other organics that can contaminate the flow path.) The length of tubing should be kept as short as possible (not more than a few feet) to minimize ozone destruction within the inlet tubing. Tygon[®], polypropylene (which may look like Teflon) and metal tubing should not be used. FEP-lined Tygon tubing, which is used inside the instrument provides the flexibility of Tygon with the inertness of FEP. A Teflon or PVDF inlet filter is highly recommended to prevent internal contamination of the tubing and absorption cell by particulate matter. The filter should be tested for ozone loss by measuring ambient ozone with and without the filter attached. Filters and filter holders are available through Ozone Solutions.

Although the instrument compensates for temperature drift, if strong temperature fluctuations are expected, as in vertical profiling applications using balloons, the instrument should be placed in a thermally insulated box.

Measurement of the Zero Offset

The electronic zero of the instrument may be measured by attaching an ozone destruction cartridge to the air inlet for a period of 5-10 minutes. For an accurate measurement, the instrument must have been turned on long enough for the internal temperature to stabilize. The observed offset, which can amount

to a few ppbv, can be corrected for by changing this calibration parameter from the front panel, as described below.

Collecting Data from the Analog Output

The data may be logged in real time using a data logger attached to the D9 connector on the back panel of the instrument. The voltage output is measured across pins #1 (+) and #6 (ground). Looking at the back of the instrument, the pin numbers for the connector are:

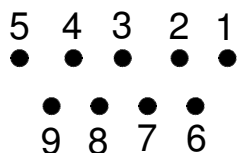

The range of the analog output is 0-2.5 V. The output is scaled according to one of three sensitivities, chosen from the microprocessor menu, as described below

Collecting Data over the Serial Port in Real Time

To transmit data to a computer over the serial port in real time, connect the Ozone Analyzer to the serial port of the computer using the 9-pin cable provided. You may use a serial-to-USB adapter if you prefer to collect data into your computer using a USB port, as most laptops no longer have serial ports. Activate your data acquisition software; e.g., Hyperterminal (available on most Windows[®]-based computers) or Tera Term Pro, which can be downloaded free from:

<http://hp.vector.co.jp/authors/VA002416/teraterm.html>

The later software is preferred since Hyperterminal has a 500-line buffer limit, but the user may set the maximum buffer size for Tera Term Pro. Both programs allow you to log the data to a computer file with no limit on number of data lines. Using these terminal emulation programs, data may be saved to a text file and then opened in Microsoft Excel (or other spread sheet program) where it may be converted to formatted data in columns by defining delimiters (such as commas and carriage returns) for data manipulation and graphing. The ozone mixing ratio (ppb), internal cell temperature (°C), cell pressure (mbar), time and date are sent as comma-delimited ASCII text to the serial port (9,600 baud; 8 bits; no parity; 1 stop bit) every ten seconds, 1 minute, 5 minutes, or 1 hour, depending on the averaging time selected from the

microprocessor menu. Time is provided in 24-hour (military) format, and the date is given in European style (day/month/year).

A typical data line would read:

67.4,309.4,759.3,18:31:27,25/06/2008

where:

Ozone = 67.4 ppbv
Cell temperature = 309.4 K
Cell pressure = 759.3 torr (1 atm = 760 torr)
Time = 6:31:27 pm
Date = October 15, 2008

If the Ozone Analyzer has been set to the log data, the output serial data line will be preceded by the log number; e.g.,

2893, 67.4,309.4,759.3,18:31:27,25/06/2008

where 2893 is the log number.

In addition to data lines, messages are written to the serial port when logging is begun or ended, when transmission of data from the logger is begun and ended, when data collection is interrupted (e.g., due to a power failure) and when the averaging time is changed.

Data Averaging and Data Logging Using the Menu

When first turned on, the instrument will start making measurements at a rate of once every 10 s. Data, along with up to three external voltages, may be logged in the internal data logger. Up to 12,288 data lines containing log number, ozone mixing ratio, internal temperature, internal pressure, time and date may be stored in internal memory, corresponding to an operational time of 1.4 days. Averaging times of 1 min, 5 min and 1 hr also may be selected from the menu, thereby allowing the instrument to operate for 8.5 days, 42 days and 1.4 years, respectively, before filling the memory.

Selecting the Menu

The menu is accessed using the Select button on the front panel of the instrument. To reach the menu hold in the Select button until

Menu, wait ...

is displayed, then release the Select button. After a few seconds the menu will appear:

Menu
Dat Ave Cfg ←

where **Dat**, **Ave** and **Cfg** are submenus that may be selected. A blinking cursor will show across the **D** of the **Dat** submenu. The Select button may be rotated clockwise or counterclockwise to move the cursor under the first letter of one of the other submenus. To select a particular submenu, move the cursor under the first letter of a submenu and momentarily press ("click") the Select button. To exit the Main Menu and begin making measurements again, select and click on the right arrow (←).

To Log Data

Select the **Dat** submenu from the Main Menu using the Select button. The display will now show:

DatMenu
Xmt Log End ←

To start logging data, rotate the Select switch to move the cursor to **Log** and click to select the logging mode. **Warning: If you start logging, all data previously stored in the logger will be irretrievably lost.** If you have data in the logger that you want to keep, be sure to download it before starting logging. To start data acquisition, select ← and click.

The Ozone Analyzer will then display a new measured ozone concentration every ten seconds, e.g.:

23.5 ppbv
Ozone

If averaging has been selected, after 5 seconds (midway between the next 10-s measurement cycle), as an example, the display will be replaced by:

Avg= 56.7 ppbv
Log= 193:4

Note: Once logging has started, you should not enter the menu, except to end logging. Entering the menu stops data acquisition, which is treated in the same way as a power failure. In particular, you should not change the averaging time while in the logging mode, as the earlier data stored in the logger memory will not be retrieved correctly.

where **Avg** is the average ozone value most recently written to the logger, and the current log number is 193. The “4” in 193:4 refers to the number of 10-s data points that have been measured so far for inclusion in the next average to be displayed and logged. If 1-min averaging is used, this number will increment from 0 to 5; for 5-min averaging, the number will increment from 0 to 29; and for 1-hr averaging, it will increment from 0 to 359. This number is displayed so that the user will know how many more 10-s measurements need to be made before a new average is displayed and logged.

If there is a power failure while the instrument is in the logging mode, logging will resume after power is restored. A note of

Data Interruption

will be written to the logger prior to writing the first new data line. The instrument can accommodate multiple data interruptions due to power failures. For example, one can purposely switch the instrument off, move to another location and restart logging simply by turning the instrument back on. Data sets will be separated by the data interrupt message.

To Stop Logging Data

Hold in the Select button to obtain the **Menu**. Go to the **Dat** submenu by clicking on **Dat**. Choose and click on the **End** function. This will end data logging. You may now transmit the data to a computer by clicking on **Xmt** (see below). Alternatively, you may return to the **Menu** by clicking on ←. The stored data will reside in memory (even when new measurements are being made) and can be transmitted using the **Xmt** function as often as you like. However, all stored data are lost once logging is started again using the **Log** function. Thus, you should always transmit your data to a computer before restarting logging.

If you fail to **End** logging prior to transmitting the data using the **Xmt** function, the instrument will automatically execute the **End** function for you prior to transmitting the data.

To Transmit Logged Data to a Computer Using the Serial Port

Connect the serial port of the instrument to the serial port of your computer using the serial port cable provided. As mentioned earlier, you may use a serial-to-USB adapter if you prefer to collect the data using a USB port. Enable a data acquisition program on the computer such as Microsoft Hyperterminal (available on most Windows® platforms) or preferably Terra Term Pro. As mentioned earlier, the disadvantage of Hyperterminal is that it has a 500 line buffer limitation, but this limitation can be circumvented by logging the data to a file as it is transmitted from the Ozone Analyzer. The correct settings for receiving data are: 9,600 baud; 8 bits; no parity; 1 stop bit.

Click the Select button to obtain the **Main Menu**. Go to the **Dat** submenu by clicking on **Dat**. Next, click on **Xmt**. The message “Logged Data” will be written to the serial port, followed by a carriage return and all of the lines of logged data. After all data are transmitted, the message “End of Logged Data” and a carriage return are written. After transmission is complete, you can return to any position in the menu or resume ozone measurements. The logged data continues to be available for transmission until a new data log is started.

To Average Data

Hold down the Select button to obtain the **Menu**. Select and click on **Avg** to obtain the **Avg** menu:

Avg Menu
10s 1m 5m 1h ←

Use single clicks to move the cursor to **10s**, **1m**, **5m** or **1h** for averaging times of 10 s (no averaging), 1 min, 5 min or 1 hr averaging, respectively. Then click on the averaging time you want to use. To return to the Main Menu, click on ←. To exit the Main Menu and start acquiring data, click on ← again.

While in averaging mode, the current 10-s measurement is displayed alternately with the average value at 5-s intervals.

Averaged data may be logged, thereby greatly extending the length of time that the data logger can be used.

To Set the Calibration Parameters

The instrument is calibrated at the factory where slope and offset parameters are entered into the instrument’s memory. These preset calibration parameters

are given in the instrument's Birth Certificate and recorded on the calibration sticker on the back of the instrument. However, the calibration parameters may be changed by the user. For example, it may be desirable to provide a positive offset by a known amount (e.g., 10 ppb) if the analog output is being used for external data logging since the analog voltage output does not go negative below zero ppb, and the current output does not go below 4 mA. Because of noise and/or an inherent offset, some measured values will be below zero at very low ozone mixing ratios or while zeroing the instrument with an external scrubber. Also, the instrument zero may drift by a few ppb over time. For this reason, frequent zeroing of the instrument using an external ozone scrubber to determine the offset is recommended. Any change in the slope (gain) of the instrument is likely due to a serious problem such as contamination, an air leak, obstruction of air flow, or loss of catalytic activity by the internal ozone scrubber, but it also can be adjusted. Once the zero of the instrument is corrected, the slope may be adjusted so that the instrument readout agrees with a standard ozone source (such as the Ozone Solutions Model 306 Ozone Calibration Source™) or with the readout from another instrument whose calibration is considered to be accurate.

To change the calibration parameters, enter the Administrative menu by holding in the Select switch while you power the instrument on. The following screen will appear:

Amin Menu
Cal I/O Nxt ←

Now use the rotary select switch to select and click on **Cal**. The following submenu with the values of the current calibration parameters will then appear:

Cal Menu
Z= -2 S= 1.01

Here Z is the offset applied (in this case -2 ppbv) and S is the slope applied (in this case 1.01). The value of Z is added to the measured ozone value, and the value of S is then multiplied by the measured ozone value. For example, if the instrument reads an average of 3 ppbv with the external scrubber in place, the value of Z should be set to -3. If after correction for the zero, the instrument consistently reads 2% low, the value of S should be set to 1.02.

When the **Cal Menu** first appears, the **Z** will be underlined with a cursor. You may rotate the Select switch to choose the calibration parameter **S** or **Z**. A single click on **S** or **Z** will select that parameter for change and activate a blinking cursor. Once **S** or **Z** is selected, its value can be changed by rotating

the Select switch to the left or right. After choosing the desired value, a click turns off the blinking cursor and allows you to scroll to the other parameter or to ← to exit the submenu. Once the values of **Z** and **S** are set, clicking on ← will return the display to the **Cfg** menu, and another click on ← will return to the **Admin Menu**. The calibration parameters reside in non-volatile memory and are not affected by power failures.

The **I/O** submenu of the **Admin Menu** allows you to enter a special service mode. In this mode, additional information is output over the serial port. The **Nxt** submenu is reserved for future software improvements and is not used at present.

To Set the Time and Date

From the **Main Menu**, select the **Cfg** submenu. Next, select the **D/T** submenu. The display will read, for example:

D/T: 14:32:21 ←
17/10/2007

meaning that it is 21 seconds after 2:32 p.m. on October 17, 2007 (military time and European date). To change a number in the date and time, rotate the Select switch to underline the numeral you want to change. A single click then causes a blinking cursor to cover that numeral. The number can then be changed by rotating the Select switch. Once the number is correct, click on the Select switch to turn off the blinking cursor. You may now rotate the Select switch to choose another numeral to change. Once the time and date is correct, clicking on ← will set the internal clock to that time and return the display to the **Cfg** menu. As in setting a digital watch, the seconds should be set in advance of the real time since the clock starts to run again only when the set time is entered; in this case by clicking on ←.

To Change the Scale for the Analog Output

As mentioned above, an analog output is provided via the D9 connector at the back of the instrument for those who want to record their data with a chart recorder or external logger. The full scale of the analog output is 2.5 V (pin #1 vs. #6 ground) or 20 mA (pin # 9 vs. #6 ground). The scaling of this output can be changed using the **ScI** submenu of the **Cfg** menu. The output voltage scaling choices are as follows:

1: Range of 0-1 ppm; 1 V = 0.4 ppm = 400 ppb

10: Range of 0-10 ppm; 1 V = 4 ppm = 4,000 ppb

100: Range of 0-100 ppm; 1 V = 40 ppm = 40,000 ppb

There may be a small positive offset, which varies from instrument to instrument. The offset can be measured by simultaneously observing the panel display and measuring the analog output with a voltmeter.

A current output is provided by pin #9 relative to ground pin #6. The current range is 4-20 mA, where 4 mA is output for 0 concentration. The current output is also scaled by the same three scaling factors chosen from the menu:

1: Range of 0-1 ppm; 4 mA = 0 ppm; 20 mA = 1 ppm

10: Range of 0-10 ppm; 4 mA = 0 ppm; 20 mA = 10 ppm

100: Range of 0-100 ppm; 4 mA = 0 ppm; 20 mA = 100 ppm

The diagram on the following page summarizes the complete menu.

To Change the Ozone Measurement Units

From the **Cfg** submenu, choose the **Unt** submenu:

O3 Units Menu
Ozone: ppb

Depress the Select switch to obtain a blinking cursor and rotate the select switch to choose between units of ppb, pphm, ppm, $\mu\text{g}/\text{m}^3$ and mg/m^3 .

To Set the Relay Limits

The Ozone Analyzer may be used to control other devices such as ozone generators using a 12 amp relay. To set the On and Off limits of the relay, choose **Rel** from the **Cfg** menu. The menu will show, for example:

On =009.900
Off=010.100 ←

With these settings the relay will close (pass current) until the ozone concentration exceeds 10.1 ppm. Above this concentration the switch relay will

open. The relay will not close again until the ozone concentration drops below 9.9 ppm. In this way, ozone concentration from an ozone generation could be controlled in the range 9.9 to 10.1 ppm, for example. You may now move the cursor using the Select switch to choose the digits in the On and Off relay settings and rotate the Select switch to change those settings.

The following diagram summarizes the Menu.

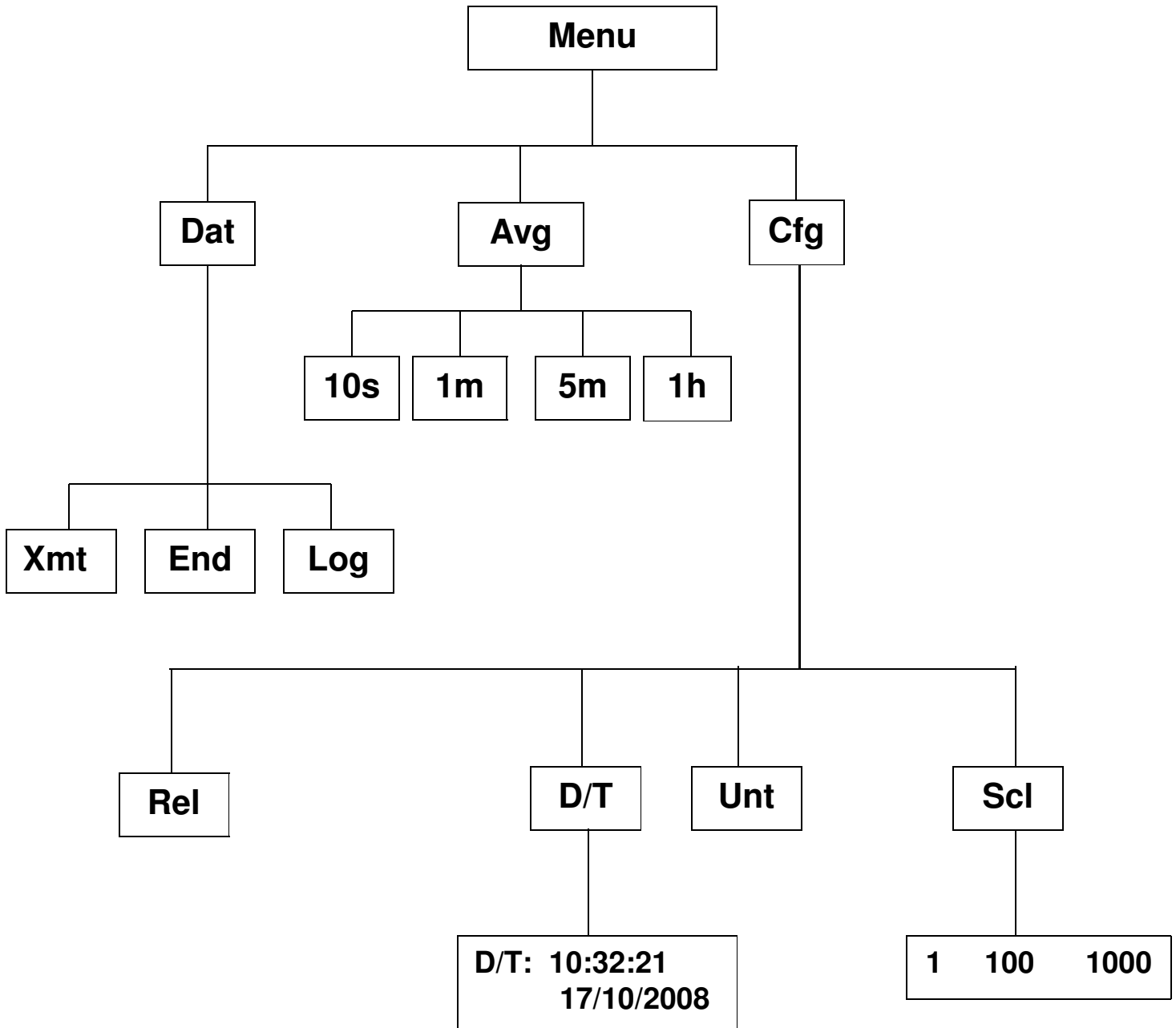

3. MAINTENANCE/TROUBLESHOOTING

The Ozone Analyzer is designed to be nearly maintenance-free. The only component that requires routine maintenance is the ozone scrubber, which should be changed at least once every six months of operation. Also, the inlet filter (user supplied) should be changed as recommended by the filter manufacturer.

To change the internal scrubber, remove the two bolts that hold the front panel in place. Now slide forward the left circuit board. The internal ozone scrubber is held in place on the circuit board by a clamp with one bolt and nut. The ozone scrubber is connected in line by two press-fit connectors.

Other components with a limited lifetime are the air pump (~5,000 hours), lamp (~20,000 hours) and solenoid valve (rarely fails). It is recommended that the instrument be returned to Ozone Solutions if any of these components fail. Alternatively, the user may install these components at their own risk. In that case, please contact Ozone Solutions for instructions.

The following are indications of various instrument malfunctions.

Air Pump Failure: The instrument will not make a humming sound. Also, the circuit breaker may prevent the instrument from powering up if the motor in the air pump develops a short.

Lamp Failure: The ozone measurements will be erratic and the Lamp Test will show 0.0 volts for the photodiode voltage.

Solenoid Valve Failure: The ozone readings will be low and average to zero if the solenoid valve is not switching. Partial switching of the solenoid valve will cause the instrument to read low but not zero.

Contaminated Flow Path: The instrument will typically have a large positive or negative offset and the ozone readings will be low once corrected for the measured offset.

Ozone Solutions offers reasonably priced customer service for instrument repairs. The calibration service includes cleaning of the entire flow path with methanol, testing of all components for proper function, installation of a new internal ozone scrubber and calibration against a NIST-traceable standard.

4. PARTS LIST

The following list includes those parts that are user serviceable.

| <u>Part Number</u> | <u>Description</u> |
|--------------------|-----------------------------------|
| SCRBINT-106 | Ozone scrubber (internal) |
| SCRBEXT-106 | Ozone scrubber (external) |
| OZLAMP-106 | Lamp and cable |
| OZVLV-106 | Solenoid valve |
| OZDSP-106 | LCD display and cable |
| OZPUMP-106 | Air pump |
| PDASSY-106 | Photodiode assembly and cable |
| OZCELL-106 | Absorption cell |
| SERCABL-106 | Serial port cable (to computer) |
| 110ADP-106 | 110 V AC adapter |
| PWRWIR | Bare wire power cable |
| 12VADP | 12 V DC cigarette lighter adapter |
| TEFTYG | Teflon-lined Tygon® tubing |
| SILTUB | Silicone tubing |

5. CONTACTING OZONE SOLUTIONS

By mail:

Ozone Solutions, Inc.

789 7th St NW

Sioux Center, IA 51250 USA

By telephone: (712) 722-0337

By fax: (712) 722-1787

By mobile phone: (712) 441-0210

By e-mail: sales@ozoneapplications.com

Website: www.ozonesupplies.com