



SM-4 Sensor Module

ECO SENSORS, INC. OZONE SWITCH™ Model OS-4

INSTRUCTIONS FOR USE

GENERAL

The model OS-4 acts like a thermostat to control ozone generators and alarms based on sensing two set-points of ozone concentrations: one to turn on the generator or alarm and the other to turn it off. There is also a .1 ppm alarm for continuous monitoring of human safety in the vicinity of the sensor. The standard available range is .05-10 ppm. The SPDT relay contacts handle up to 5 amps at 250 volts. The OS-4 also has digital, voltage and 4-20 mA outputs to drive remote monitors and control systems. The OS-4 should not be used in the presence of acid gases, strong VOC's, strong halogen fumes, silicones or sulfur compounds.

Do not open or service the sensor module when any power is connected to the OS-4 or its sensor module. This will damage the sensor calibration memory.

The instrument is conditionally warranted for one year. Save a copy of your purchase document as a proof of purchase and date, and read the warranty statement at the end of this manual.



OS-4 Host Unit

OPERATION

First, verify that the instrument is working as received. Verify that a sensor module is wired to the OS-4 main instrument processor. The other terminal blocks and set-point controls are found on the inside back of the instrument (remove cover to access them).

Connect your AC adapter to the power jack or your 8-24 VDC supply to terminals + and GND of the terminal block TB4. The green LED **Power** indicator should light and digits should show on the display.

In order to burn off any chemicals that the sensor may have absorbed during shipping and storage, you should let the OS-4 run with power on and the sensor module connected for 1 hour before response testing or overnight before the first use on site. It is recommended to test the instrument for positive response with an ozone generator when the instrument is received and again at the site where the instrument is installed. Eco Sensors, Inc. offers an inexpensive hand-held ozone generator for this test purpose, the model OG-1.

You can now connect the Ozone Switch™ to an external device such as an ozone generator, alarm or PLC. See **OUTPUTS TO EXTERNAL EQUIPMENT** below. Bring the external wiring through the access hole on the bottom of the enclosure.

CALIBRATION

The OS-4 uses a calibration concept that is somewhat novel: The ozone sensor is mounted on a sensing board, called the SM-X, includes a microprocessor and EEPROM memory. The exact calibration curve for that particular ozone sensor is burned into the EEPROM along with a calibration date and serial number. The OS-4 host instrument adjusts the sensor readings for temperature and relative humidity based on data sent from the sensor module. The SM-X sensor board is disposable or recalibratable based on the user's cost and time-out-of service considerations, and it plugs into a larger board in a small enclosure called the SM-4 module which can be up to 30 meters (100 feet) from the OS-4.

In most cases, it is probably cheaper and faster to replace the SM-X sensor board with a freshly calibrated one than to send the current old one back for recalibration. Also the SM-X board can NOT be recalibrated in the field. It can only be done by a special computer at Eco Sensors, Inc.

The SM-X calibration can be checked by the Eco Sensors OG-3 calibration checker. The calibration is within 20% over the sensor's range.

OUTPUTS TO EXTERNAL EQUIPMENT

The OS-4 has a variety of outputs to external equipment. Referring to the terminal blocks accessed by opening the instrument's cover panel, these are:

1 - SAFETY LIMIT OF .1 PPM EXCEEDED IN SENSOR AREA. Internal relay connected to TB2 is activated and panel yellow LED comes on. The relay has 5 A 250 volt rated contacts.

2 - RELAY (USUALLY CONTROLLING AN OZONE GENERATOR): Normally open and normally closed contacts accessed on TB1. The set points for this relay are labeled HIGH LIMIT and LOW LIMIT. The HIGH LIMIT **must always be greater than** LOW LIMIT **and the low limit should always be above 0**. (If the high limit was inadvertently set below the low limit, the panel green LED will flash). This relay has 5 A 25 volt contacts. It is recommended that for all but the smallest generators that this relay control a larger power-handling relay located in the generator power wiring area.

3 - RS-232 OUTPUT DATA.

4 - ANALOG OUTPUT (VOLTAGE). Gnd and 0-2 terminals on TB3. Usually for driving small data loggers.

5 - ANALOG OUTPUT (4-20 MA). Gnd and 4-20 on TB3. Usually for driving a PLC (programmable logic controller) system controller.

SERVICE AND MAINTENANCE

Do not attempt to do board level repairs or microprocessor programming yourself. This will void the warranty. We recommend checking the calibration monthly and replacing the sensor module annually. General repairs should be done at the factory or by an Eco Sensors authorized service representative.

Calibration of the sensor on its board (SM-X) is done by computer in a special laboratory at the factory. Therefore in most cases it is lowest cost to replace the SM-X board than to request that it be recalibrated.

Instruments with problems during the warranty period should be returned as system (OS-4 and SM-4) to the factory or authorized service representative for diagnosis and repair.

AC ADAPTER

For use in 120 V 60 HZ areas, the Eco Sensors P-20 adapter should be used. For other areas adapters should be purchased local that fit local wall sockets and conform to local codes. The output should be 12 volts DC unregulated, 300-500 mA. The plug to our instrument should fit a 5.5/2.5 mm socket with the center pin +. For further details see our Tech Note P-101.

SPECIFICATIONS

Sensor: Heated metal oxide semiconductor.

Sensitivity: First responds at .05 few ppm

Response time: Within one minute of when gas reaches the sensor.

Temperature and humidity range: 0-40 deg C and 0-80% relative humidity.

Supply voltage required: 8-24 volts DC, 300 mA. Ground -.

Adapter plug: 5.5 mm/2.5 mm female, center +.

Size of instrument: 128 (H) X 64 (W) X 38 mm (D) (5.03" X 2.52" X 1.50").

Weight of instrument: 140 grams (5 oz.).

Size of SM-4 Sensor Module 76 mm (H) X 64 mm (W) X 29 mm (D) (3.00" X 2.50" X .1.12")

Horizontal mounting centers: 73 mm (2.87")

Cable from SM-4 sensor module to OS-4 instrument host unit: Up to 100 feet (30 meters) 3 conductor cable such as used for indoor telephone wiring. Wires preferably are color coded red, black and white to correspond with the terminal block notations.

SAFETY FEATURES

Human safety alert: LED illuminates and a relay is activated if sensor is in >.1 ppm ozone.

Loss of power protection: Relay opens (shuts off generator) when the instrument loses power.

Enclosure: Self-extinguishing ABS plastic. *Relays:* UL, CSA and CE approved.

Sensor: Heated element is flame arrestor protected.

Electrical: (a) Circuits operate at 12-24 volts (b) Self-resetting fuse to protect against excess input current flow. (d) Overvoltage protection diode barrier to protect against supply voltage surges, spikes, overvoltage, and reverse polarities.

PRECAUTIONS

- Do not open or service the sensor module or board with power connected to either the OS-4 or the sensor module.
- Allow at least 1-4 hours warm-up for functionality testing and 24 hours warm-up for operational use.
- Read all instructions in this manual.
- Keep instrument dry. Never let water or other liquids into the sensor.
- Do not drop the instrument or subject it to continuous vibration.
- Do not store in high levels of dust.
- Do not clean the instrument with cleaning chemicals or solvents. Clean it with a damp cloth.
- Do not operate near heavy aerosols (spray) usage or where oxygen is being administered.

- Call a qualified electrician if you have any doubts about voltages, currents, electrical practice, etc.
- Do not operate the instrument or rely on its readings where there are high concentrations of:
 - Chlorine or other halogen compounds
 - Sulfur compounds
 - Strong VOCs such as solvent vapors.
 - Silicone compounds such as RTV.
 - Urine residues and ammonia compounds
 - Acid gases such as sulfuric acid or nitric acid fumes.
- Keep at least a meter above fruit in food storage applications to avoid the negative influence of ethylene ripening agent emitting from the fruit.

When in doubt, operate the instrument in your worst case conditions for at least 24 hours to see if it will operate properly.

WARRANTY

This product is warranted against defects in materials and workmanship for one year following the date of purchase by the original owner. This warranty does not include damage to the product as a result of misuse, accident, damage, modifications or alterations, and it does not apply if the instructions in this manual are not followed.

If a defect develops during the warranty period, Eco Sensors at its election will repair the instrument or replace it with a new or reconditioned model of equivalent quality. In the event of replacement with a new or reconditioned instrument, the replacement unit will continue the warranty of the original unit.

If the product should become defective during the warranty period, please return it through your distributor, or call Eco Sensors at (800) 472-6626 or e-mail at sales@ecosensors.com to receive return instructions and a Return Goods Authorization (RGA) number.

Except as provided herein, Eco Sensors makes no warranties, express or implied, including warranties of merchantability and fitness for a particular purpose. Eco Sensors shall not be liable for loss of use of this instrument or other incidental or consequential damages, expenses or economic loss, or claims for such damage or economic loss.

This warranty gives you specific legal rights, and you may also have other rights which vary from state to state.

RECORD YOUR SERIAL NUMBER HERE _____

KEEP THIS MANUAL AND WARRANTY FOR YOUR RECORDS.

Eco Sensors is a registered trademark of Eco Sensors, Inc.

© Eco Sensors, Inc. 2005. OS-4 REV 1, SM-4 and SM-X, Manual rev 11/05

For brochures, application and tech notes, and other useful information, visit our extensive website at www.ecosensors.com. E-mail us at sales@ecosensors.com.

APPENDIX A

WIRING TO THE OS-4 HOST PROCESSOR

AND THE SM-4 REMOTE SENSOR MODULE

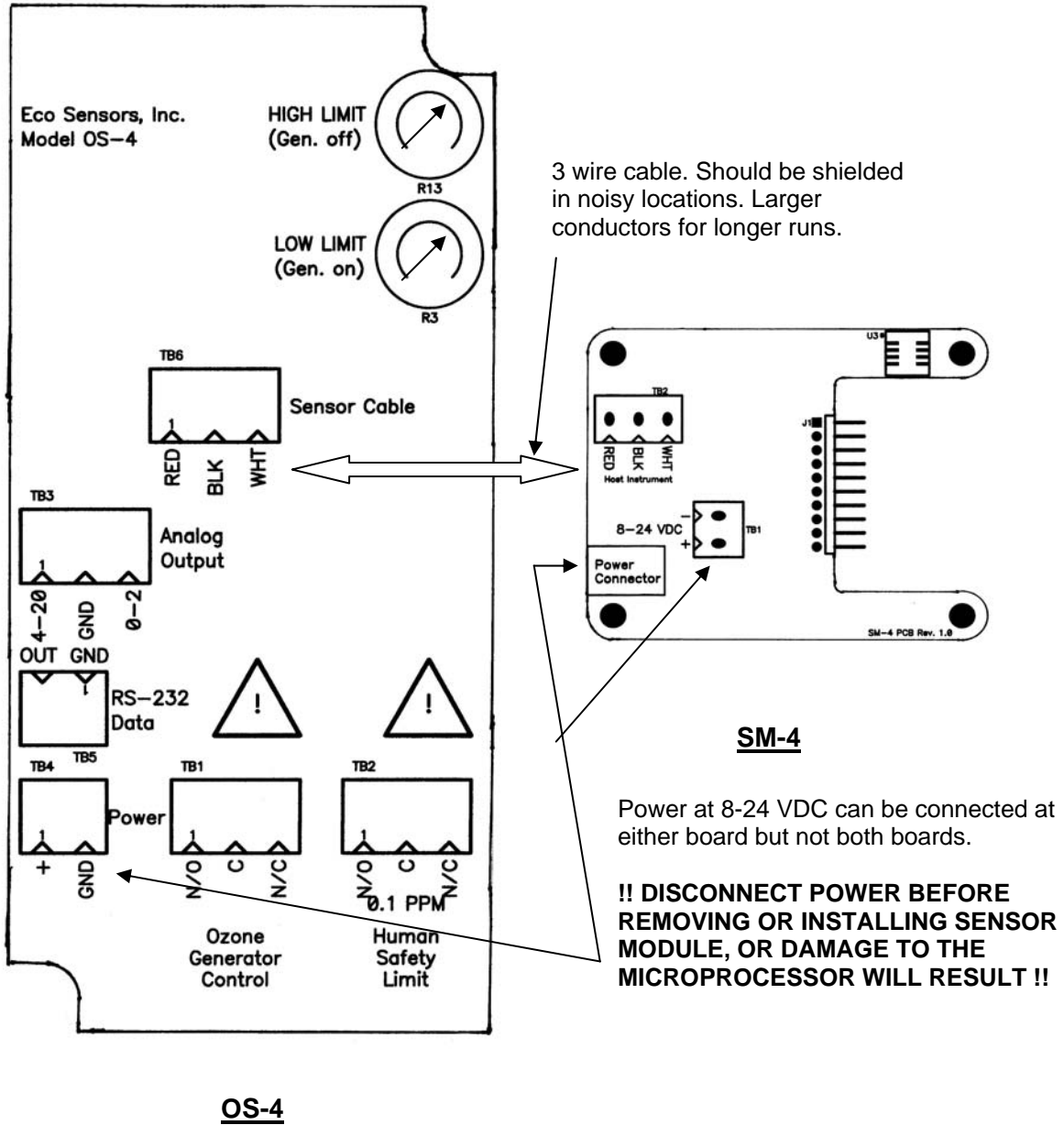

APPENDIX B**REPLACING THE SENSOR MODULE**

- 1- Locate SM-4 sensor module and put on workbench.

Sensor mounting centers are
23 mm (2 7/8")

**IMPORTANT!!**

- 2 - **Disconnect power cable at OS-4 or SM-4 (wherever it is connected).**

- 3 - Remove back cover.

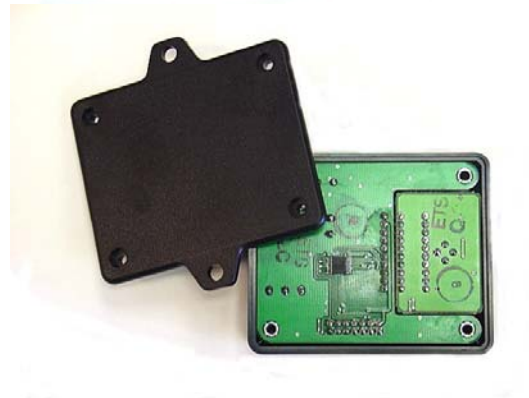

- 4 - Examine SM-4 board.

- 5 - Check for tight connections at the terminal block.

+8-24V Gnd Signal
Red Black White

Terminal block and
power jack for powering
at sensor module end
instead of OS-4

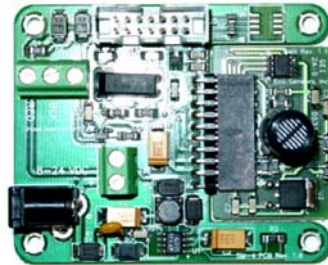

- 6 - Carefully replace SM-X sensor module. Reassemble SM-4 module. Connect power.

