

System Flow Diagram

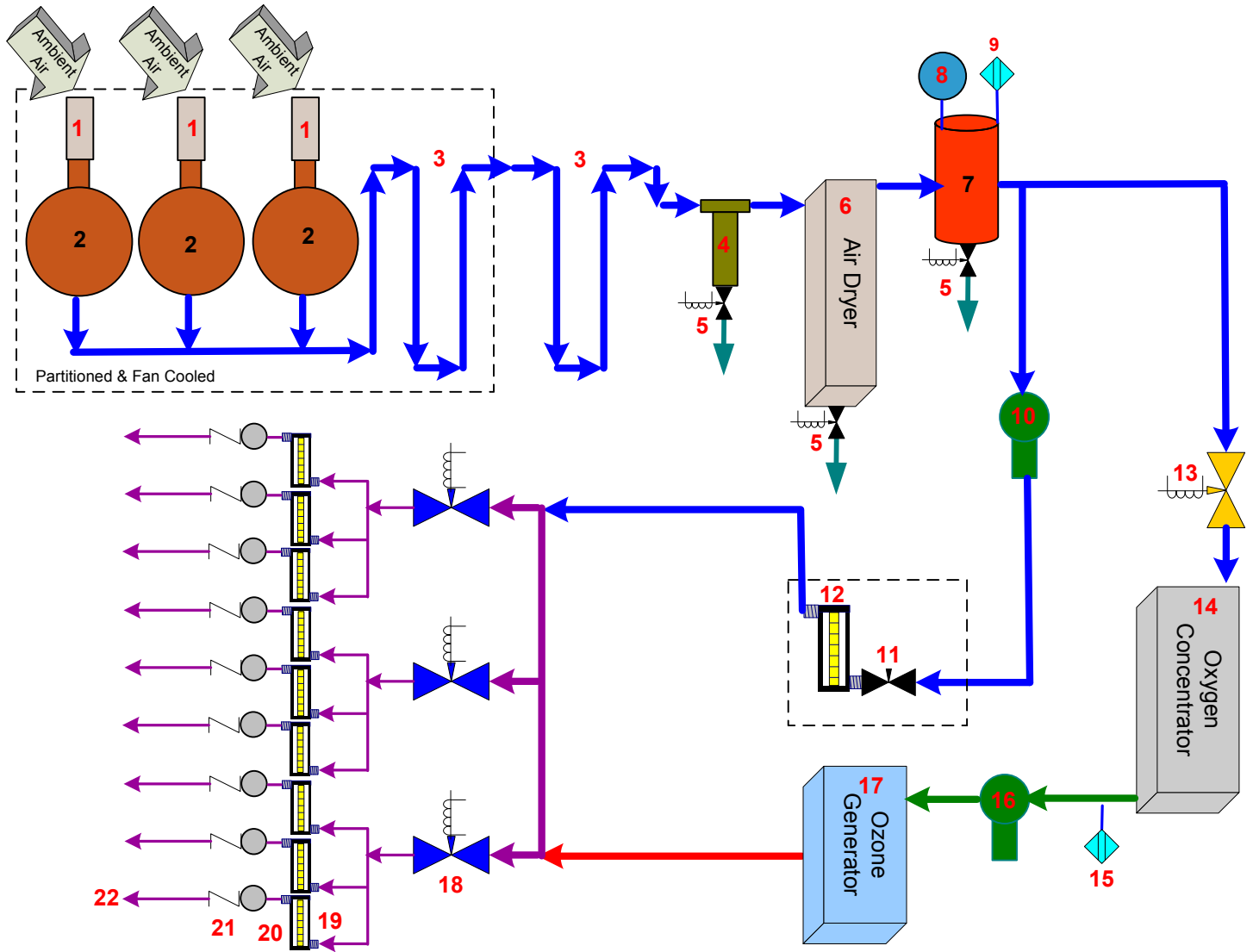

- | | |
|-----------------------------------|--|
| 1. Air Inlet Filter | 12. Sparge Air Flowmeter |
| 2. Air Compressor | 13. Air Valve (O2 Concentrator supply) |
| 3. Compressed Air Cooling Coil | 14. Oxygen Concentrator (O2 Conc) |
| 4. Coalescing Filter | 15. Oxygen Pressure Transducer |
| 5. Solenoid Valve Drain | 16. Oxygen Back-Pressure Regulator |
| 6. Refrigerant Air Dryer | 17. Ozone Generator |
| 7. Air Storage Tank | 18. Manifold Solenoid Valves |
| 8. Air Pressure Gauge | 19. Well Output Flowmeters |
| 9. Air Pressure Transducer | 20. Well Output Pressure Gauges |
| 10. Air Back-Pressure Regulator | 21. Well Output Check Valves |
| 11. Sparge Air Flow Control Valve | 22. Well Output bulkhead fittings |

Ozone Solutions
 712-439-6880
www.ozonesolutions.com
tech@ozonesolutions.com